

***MTA1 CAN, M1 10Prog CAN, AT1 CAN,  
AT1 CoarseFine CAN, M1, AT1, AT1  
CourseFine, RA 12, RA 23, RA T1, FS  
002 CAN, FS 002***



**Instruction manual**

<b>1 INTRODUCTION</b> .....	<b>3</b>
1.1 Equipment .....	3
<b>2 OPERATION</b> .....	<b>3</b>
2.1 Functions .....	3
<b>3 ORDERING SPARE PARTS</b> .....	<b>5</b>
<b>DIMENSION DRAWING</b> .....	<b>6</b>
<b>DIAGRAM</b> .....	<b>8</b>
<b>ORDERING NUMBER</b> .....	<b>13</b>
<b>ACCESSORIES</b> .....	<b>14</b>

# 1 INTRODUCTION

These remote controls can control current, wire feed speed, voltage or program selection.

ESAB's accessories for the product can be found on page 14.

## 1.1 Equipment

The remote controls are supplied with an instruction manual.



FS 002 CAN and FS 002 are delivered with 5 metres connection cable, for the other remote controls shall the connection cable be ordered separated.



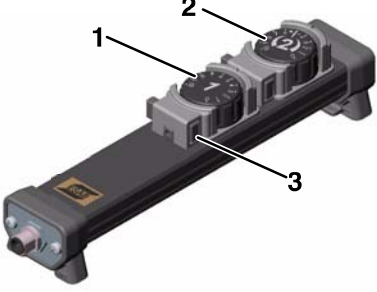
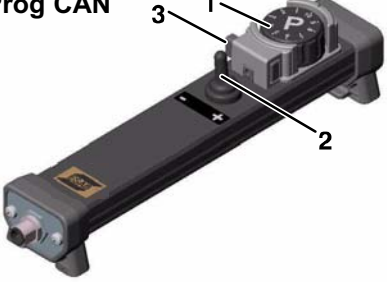

# 2 OPERATION

Connect the remote control unit to the socket for the remote control on the power source or the wire feed unit.

When connecting a remote control in a Aristo machine produced before 2005. The software of the control panel must in some cases be upgraded in order for the remote controls to function correctly.

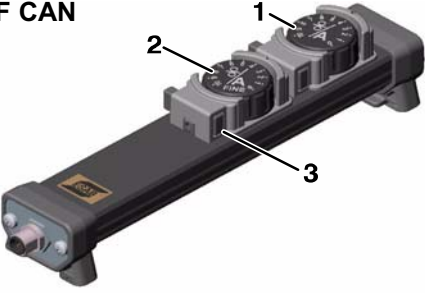
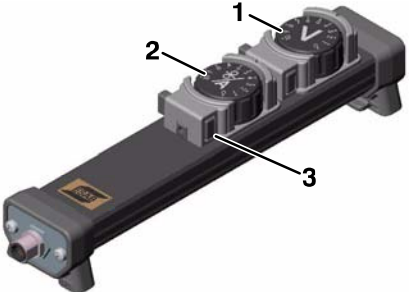
## 2.1 Functions

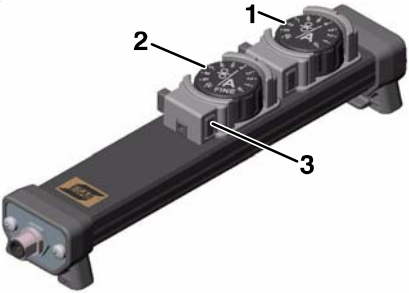
<p><b>MTA1 CAN</b></p> 	<p>CAN-based remote control for MIG/MAG, TIG and MMA welding.</p> <p><b>1 MIG/MAG:</b> Setting wire feed speed  <b>TIG:</b> Setting current  <b>TIG pulse:</b> Setting pulse current  <b>MMA:</b> Setting current</p> <p><b>2 MIG/MAG:</b> Setting voltage or voltage deviation +/- from the synergic line  <b>TIG:</b> No function  <b>TIG pulse:</b> Setting background current  <b>MMA:</b> Setting arc force</p> <p><b>3</b> Locking knob</p>
<p><b>M1 10Prog CAN</b></p> 	<p>CAN-based remote control for MIG/MAG, TIG and MMA welding.</p> <p><b>1</b> Choice of one of 10 program selections</p> <p><b>2 MIG/MAG:</b> Voltage deviation +/- from selected program  <b>TIG and MMA:</b> Setting welding current +/- from selected program  <b>TIG pulse:</b> Setting pulse current +/- from selected program</p> <p><b>3</b> Locking knob</p>
<p><b>AT1 CAN</b></p> 	<p>CAN-based remote control for MMA and TIG welding.</p> <p><b>1</b> Setting current</p> <p><b>2</b> Locking knob</p>

<p><b>AT1 CF CAN</b></p> 	<p>CAN-based remote control for MMA and TIG welding.</p> <ul style="list-style-type: none"> <li>1 Rough setting of current</li> <li>2 Fine setting of current</li> <li>3 Locking knob</li> </ul>
<p><b>M1</b></p> 	<p>Remote control for MIG/MAG welding</p> <ul style="list-style-type: none"> <li>1 Setting voltage</li> <li>2 Setting wire feed speed</li> <li>3 Locking knob</li> </ul>
<p><b>AT1</b></p> 	<p>Remote control for MMA and TIG welding</p> <ul style="list-style-type: none"> <li>1 Setting current</li> <li>2 Locking knob</li> </ul>
<p><b>AT1 CF</b></p> 	<p>Remote control for MMA and TIG welding</p> <ul style="list-style-type: none"> <li>1 Rough setting of current</li> <li>2 Fine setting of current</li> <li>3 Locking knob</li> </ul>
<p><b>RA 12</b></p> 	<p>CAN-based remote control adapter. Used for connecting remote controls MMA1, MMA2 to CAN-based equipment.</p> <ul style="list-style-type: none"> <li>1 12-pole socket</li> </ul>
<p><b>RA 23</b></p> 	<p>CAN-based remote control adapter. Used for connecting welding gun with RS3 program selector, MIG2 (2 knobs) to CAN-based equipment.</p> <ul style="list-style-type: none"> <li>1 23-pole socket</li> </ul>

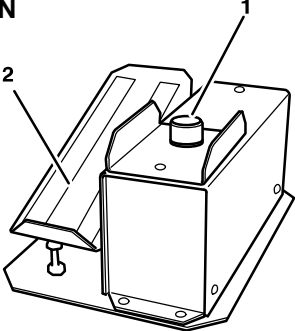
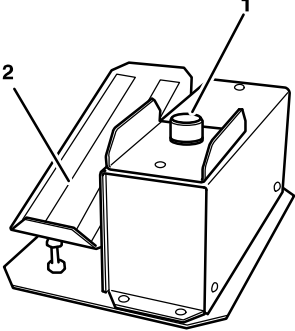
<p><b>RA T1</b></p> 	<p>CAN based adapter, used for connection of TIG torches with +/- function for CAN based equipment.</p> <p><b>NOTE!</b> Supplied with holder and 0.25 m cable.</p>
<p><b>FS 002 CAN</b></p> 	<p>CAN-based remote control for TIG welding.</p> <p>1 Potentiometer for setting of welding current, positions 1 - 10</p> <p>2 Foot pedal for weld start and setting of welding current.</p> <p>If potentiometer is set at position 10, the current is set, from min. to max. with the foot pedal</p> <p>If potentiometer is set at position 5, the current is set, from min. to 50% of max. current with the foot pedal.</p>
<p><b>FS 002</b></p> 	<p>Remote control for TIG welding.</p> <p>1 Potentiometer for setting of welding current, positions 1 - 10</p> <p>2 Foot pedal for weld start and setting of welding current.</p> <p>If potentiometer is set at position 10, the current is set, from min. to max. with the foot pedal</p> <p>If potentiometer is set at position 5, the current is set, from min. to 50% of max. current with the foot pedal.</p>

### 3 ORDERING SPARE PARTS



**CAUTION**

*All guarantee undertakings from the supplier cease to apply if the customer himself attempts any work in the product during the guarantee period in order to rectify any faults.*

Spare parts may be ordered through your nearest ESAB dealer, see the last page of this publication.

Dimension drawing

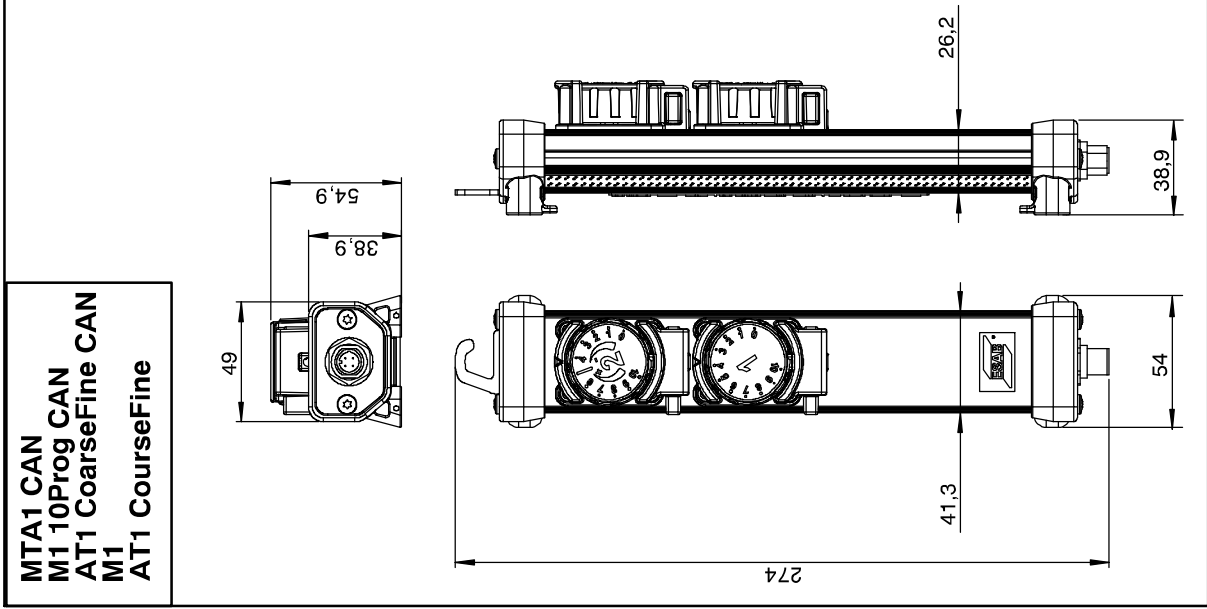
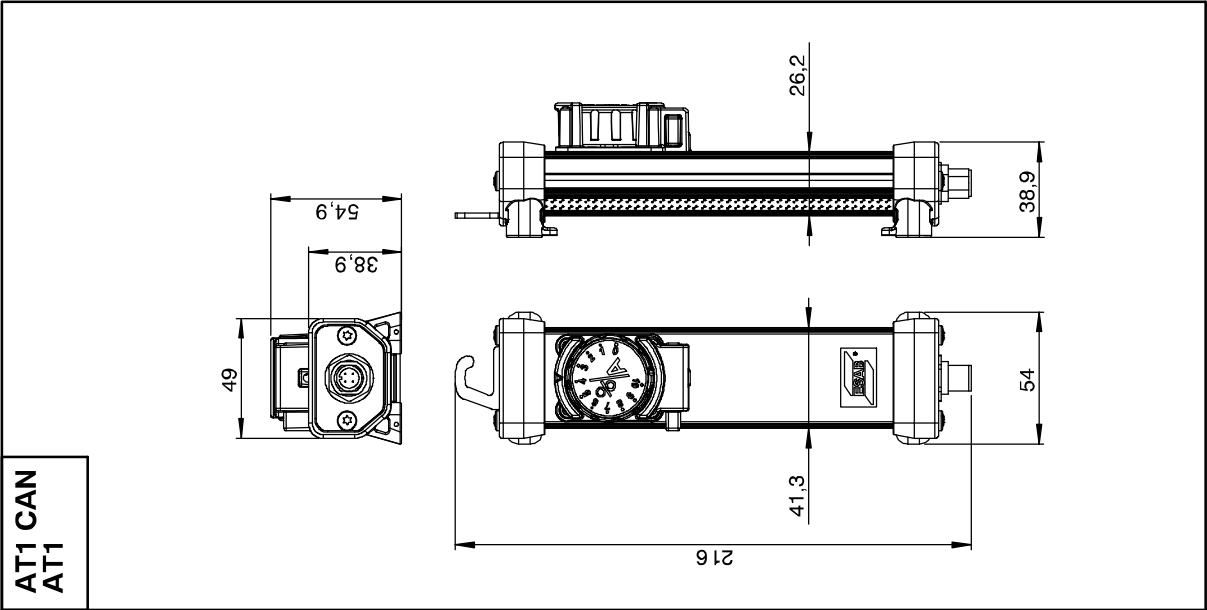
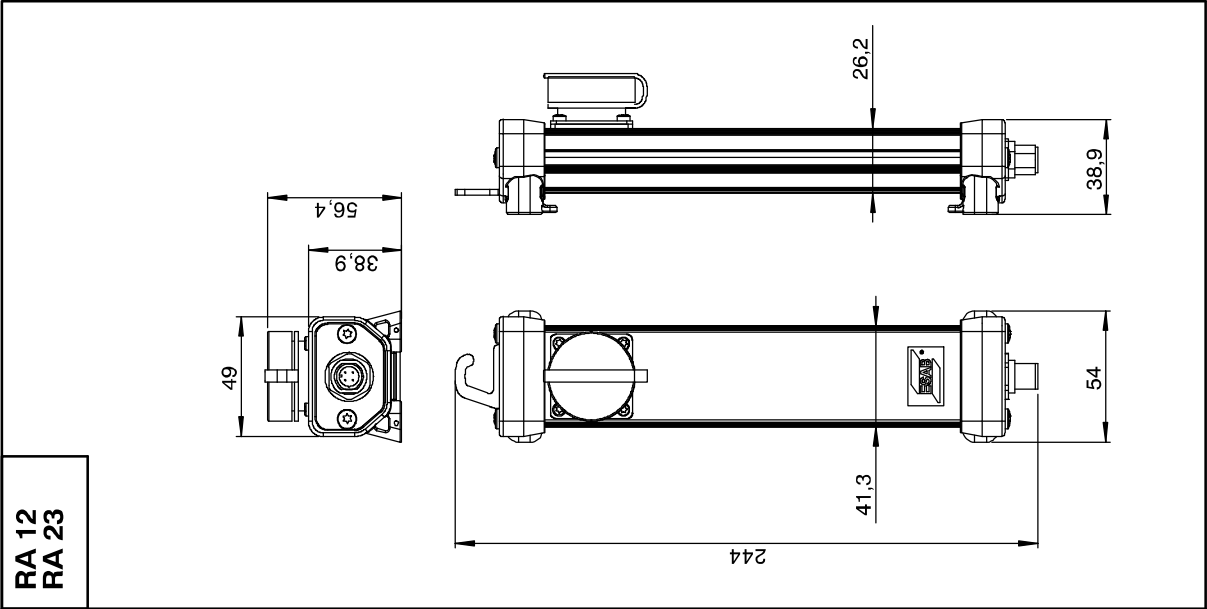

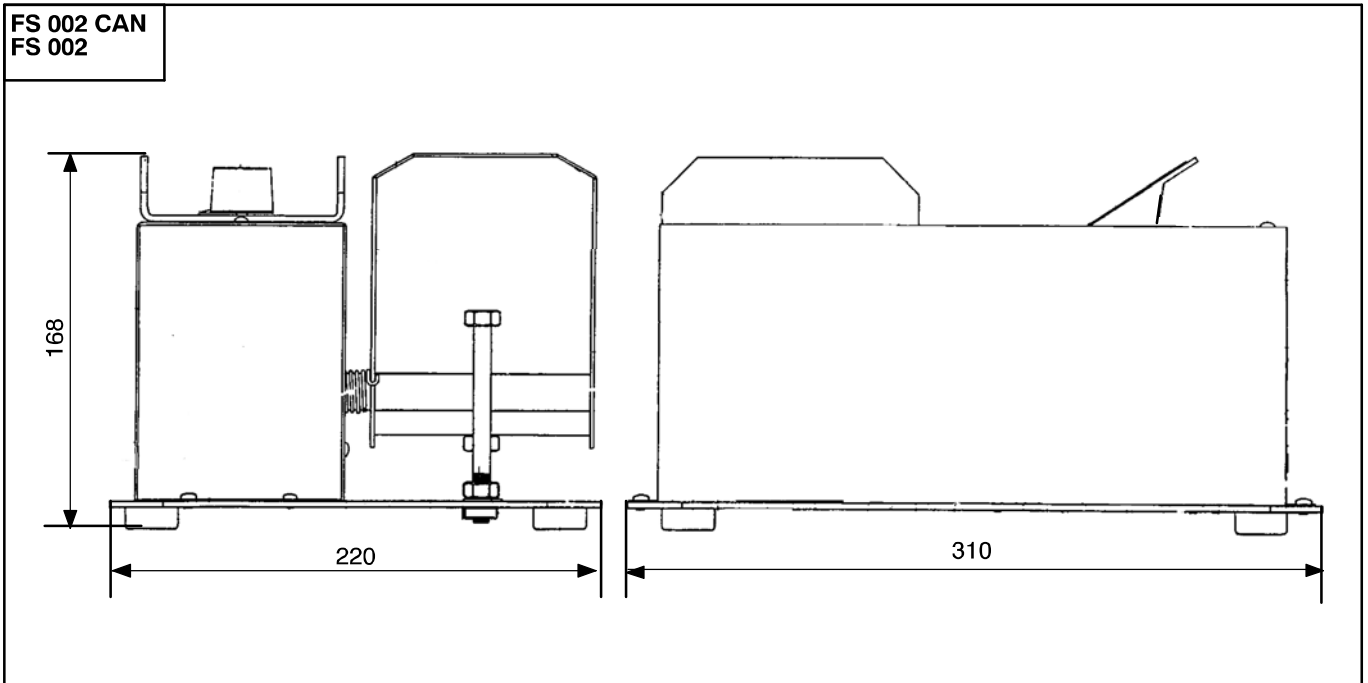
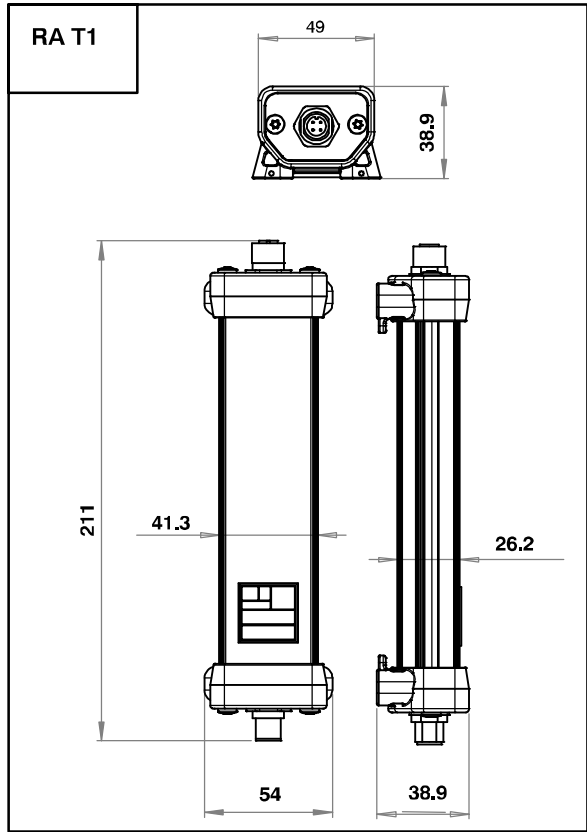

# Diagram

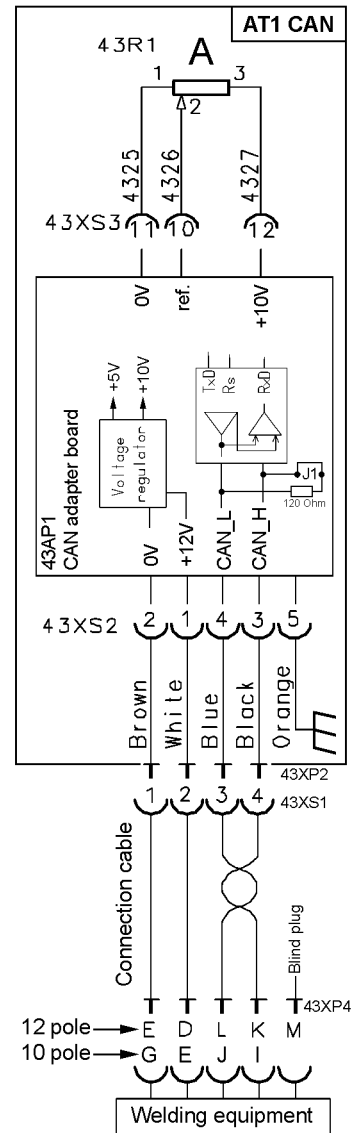
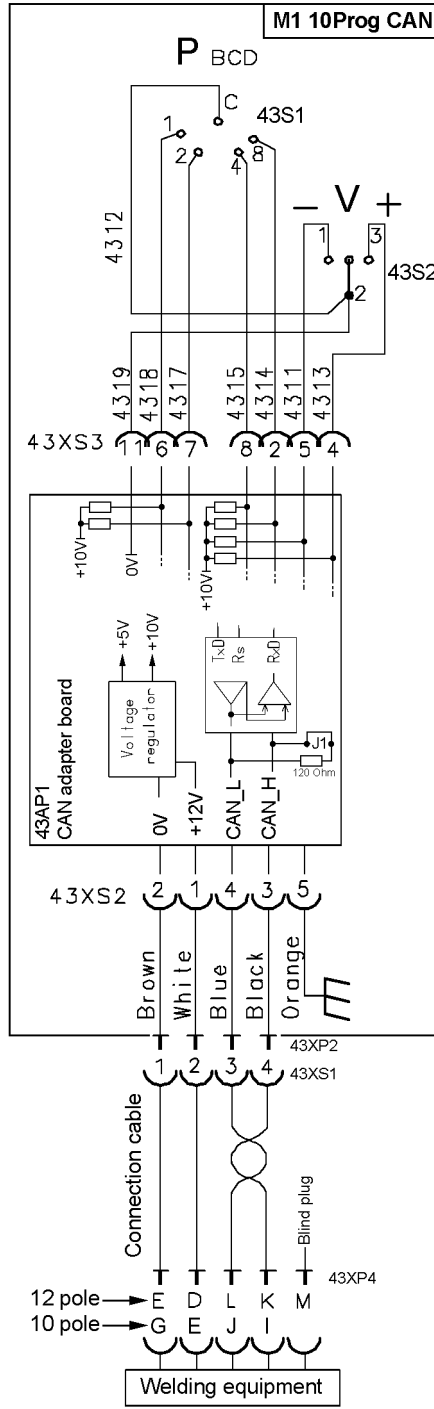
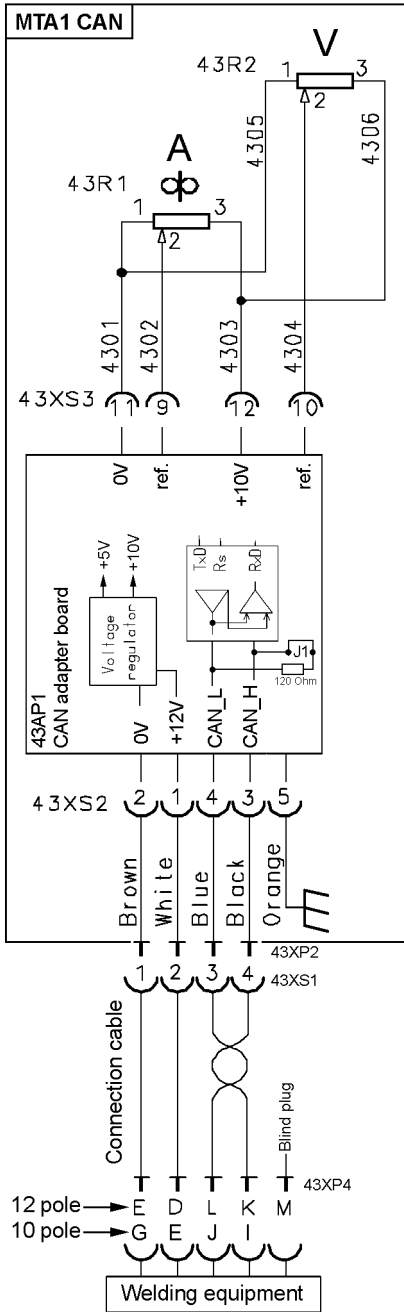





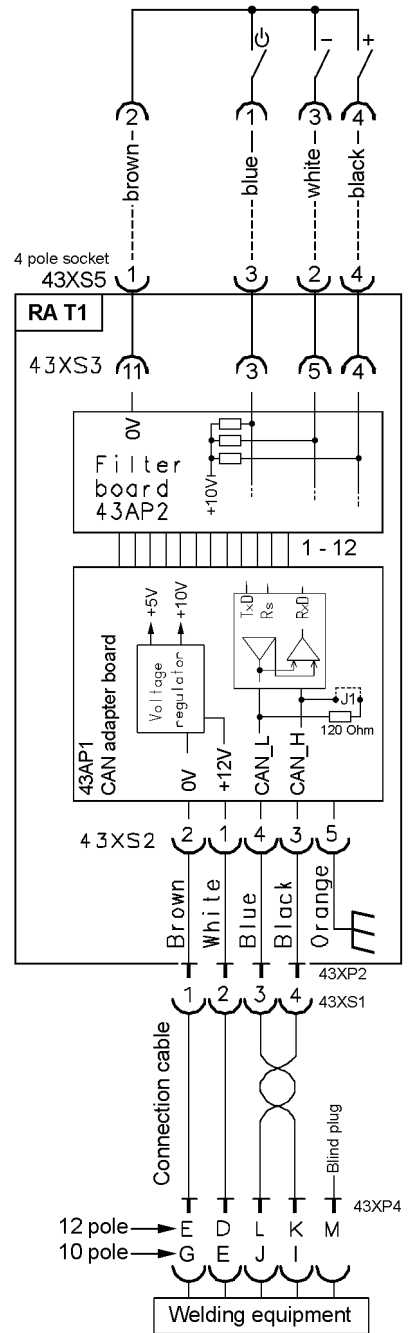
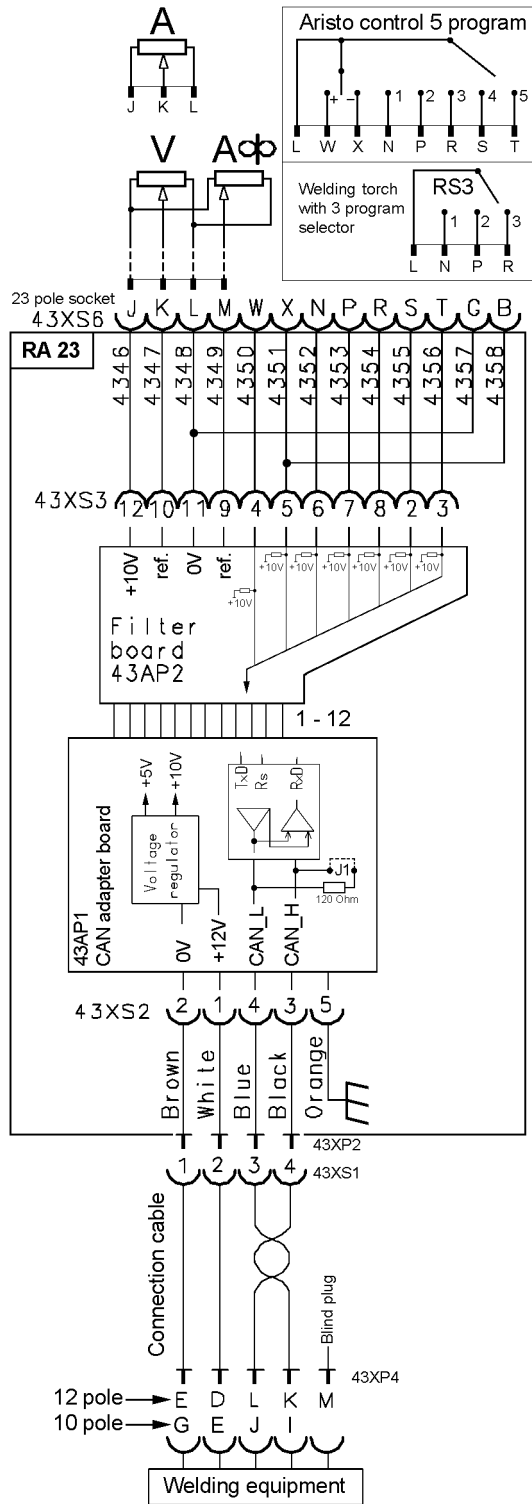

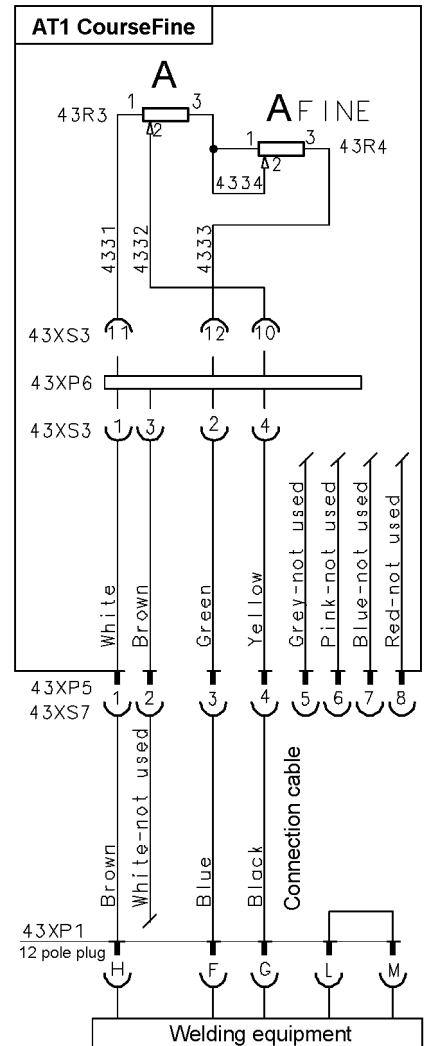
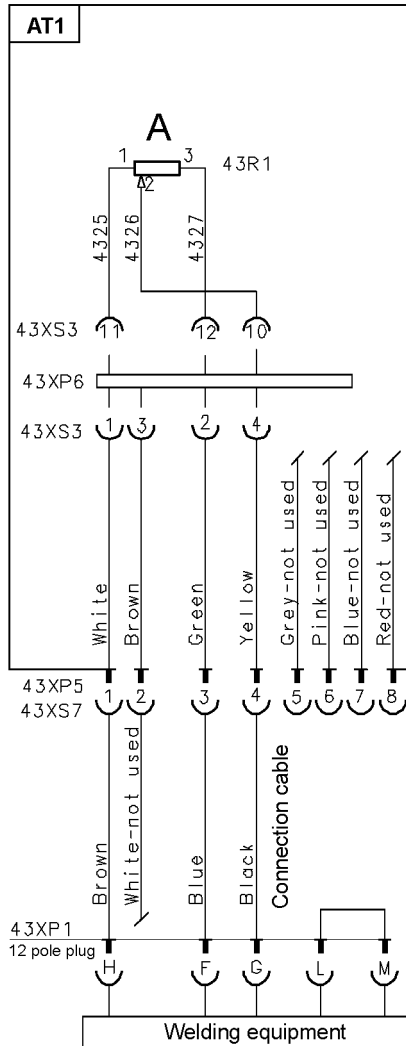
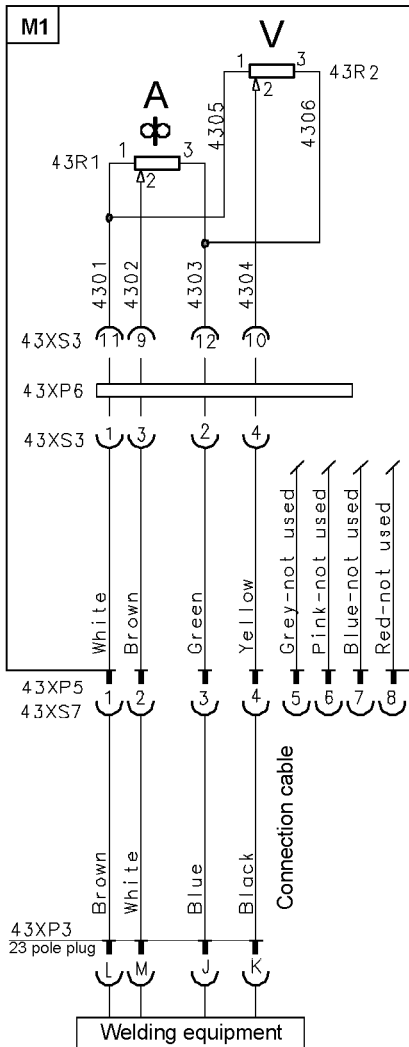

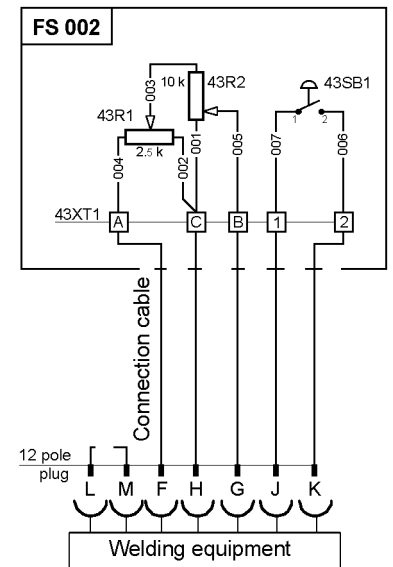
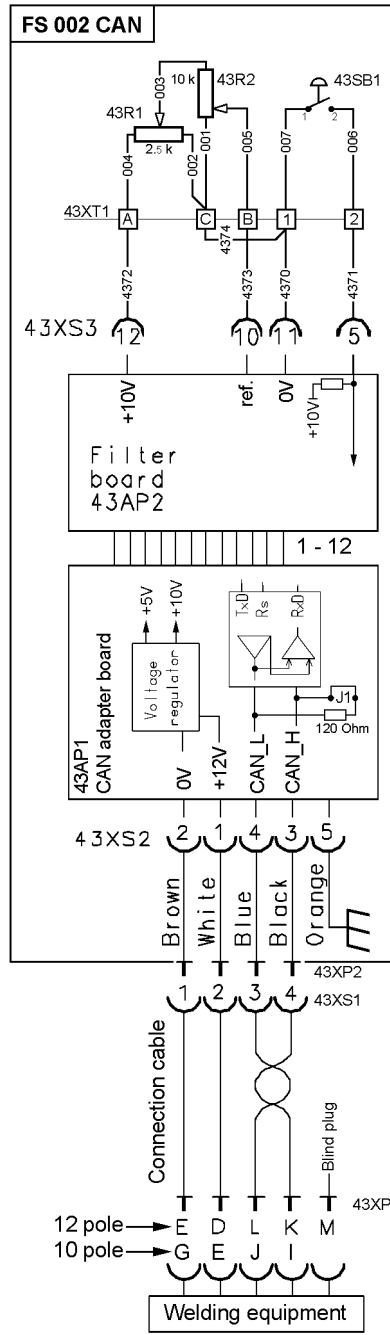
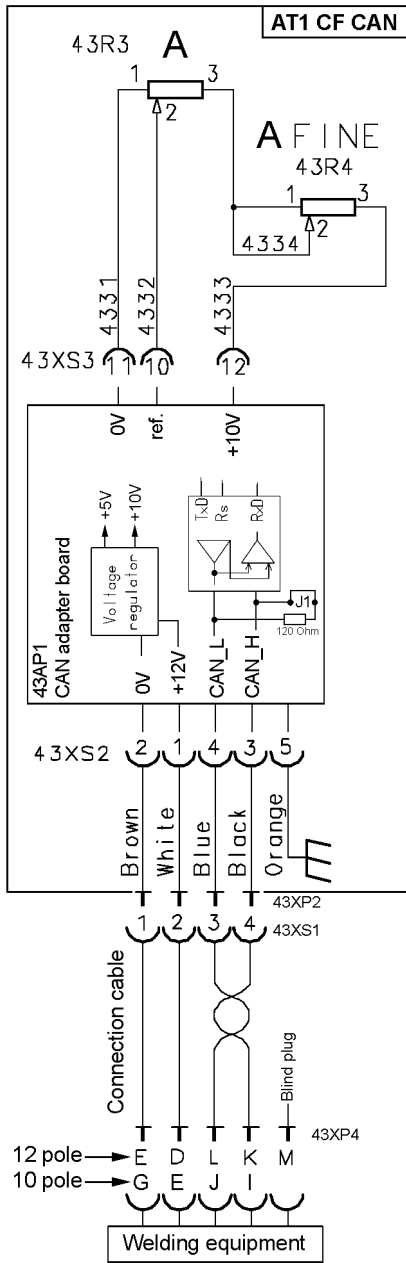

Ordering number

Remote control	Ordering no.	Remote control	Ordering no.
<b>MTA1 CAN</b> 	0459 491 880	<b>M1</b> 	0459 491 895
<b>M1 10Prog CAN</b> 	0459 491 882	<b>AT1</b> 	0459 491 896
<b>AT1 CAN</b> 	0459 491 883	<b>AT1 CoarseFine</b> 	0459 491 897
<b>AT1 CoarseFine CAN</b> 	0459 491 884	<b>RA 12</b> 	0459 491 910
<b>FS 002 CAN</b> 	0349 090 890	<b>RA 23</b> 	0459 491 911
<b>FS 002</b> 	0349 090 886	<b>RA T1 12 pole</b> 	0459 491 912
		<b>RA T1 10 pole</b> 	0459 491 913

Spare parts list 0459 576 990

The spare parts list is available on the Internet at [www.esab.com](http://www.esab.com)

**MTA1 CAN, M1 10P CAN, AT1 CAN, AT1 CF CAN, RA 12, RA 23, RA T1, M1, AT1, AT1 CF, FS 002 CAN, FS 002**

**Accessories**

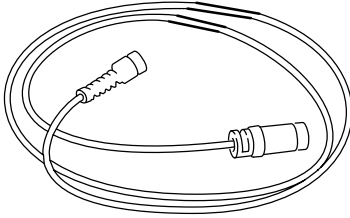
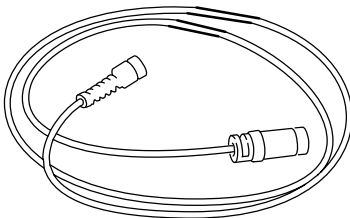
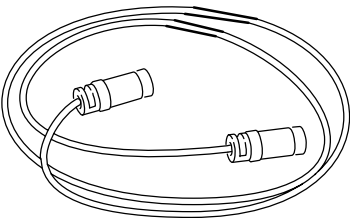
	<p><b>Remote cable CAN 4 pole - 12 pole</b></p> <p>0.25 m ..... 0459 554 884</p> <p>5 m ..... 0459 554 880</p> <p>10 m ..... 0459 554 881</p> <p>15 m ..... 0459 554 882</p> <p>25 m ..... 0459 554 883</p> <p>5 m Heavy Duty ..... 0459 554 980</p> <p>10 m Heavy Duty ..... 0459 554 981</p> <p><b>Remote cable CAN 4 pole - 10 pole</b></p> <p>0.25 m ..... 0459 960 883</p> <p>5 m ..... 0459 960 880</p> <p>10 m ..... 0459 960 881</p> <p>25 m ..... 0459 960 882</p> <p>5 m Heavy Duty ..... 0459 960 980</p> <p>10 m Heavy Duty ..... 0459 960 981</p> <p>25 m Heavy Duty ..... 0459 960 982</p>
	<p><b>Remote cable 8 pole - 12 pole for remote controls AT1 and AT1 CF</b></p> <p>5 m ..... 0459 552 880</p> <p>10 m ..... 0459 552 881</p> <p>15 m ..... 0459 552 882</p> <p>25 m ..... 0459 552 883</p> <p><b>Remote cable 8 pole - 23 pole for remote control M1</b></p> <p>5 m ..... 0459 553 880</p>
	<p><b>Extension cable 12 pole for remote controls AT1, AT1 CF and FS 002</b></p> <p>25 m ..... 0367 662 880</p>



# ESAB subsidiaries and representative offices

<b>Europe</b> <b>AUSTRIA</b> ESAB Ges.m.b.H Vienna-Liesing Tel: +43 1 888 25 11 Fax: +43 1 888 25 11 85  <b>BELGIUM</b> S.A. ESAB N.V. Brussels Tel: +32 2 745 11 00 Fax: +32 2 745 11 28  <b>BULGARIA</b> ESAB Kft Representative Office Sofia Tel/Fax: +359 2 974 42 88  <b>THE CZECH REPUBLIC</b> ESAB VAMBERK s.r.o. Vamberk Tel: +420 2 819 40 885 Fax: +420 2 819 40 120  <b>DENMARK</b> Aktieselskabet ESAB Herlev Tel: +45 36 30 01 11 Fax: +45 36 30 40 03  <b>FINLAND</b> ESAB Oy Helsinki Tel: +358 9 547 761 Fax: +358 9 547 77 71  <b>FRANCE</b> ESAB France S.A. Cergy Pontoise Tel: +33 1 30 75 55 00 Fax: +33 1 30 75 55 24  <b>GERMANY</b> ESAB GmbH Solingen Tel: +49 212 298 0 Fax: +49 212 298 218  <b>GREAT BRITAIN</b> ESAB Group (UK) Ltd Waltham Cross Tel: +44 1992 76 85 15 Fax: +44 1992 71 58 03  ESAB Automation Ltd Andover Tel: +44 1264 33 22 33 Fax: +44 1264 33 20 74  <b>HUNGARY</b> ESAB Kft Budapest Tel: +36 1 20 44 182 Fax: +36 1 20 44 186  <b>ITALY</b> ESAB Saldatura S.p.A. Bareggio (Mi) Tel: +39 02 97 96 8.1 Fax: +39 02 97 96 87 01  <b>THE NETHERLANDS</b> ESAB Nederland B.V. Amersfoort Tel: +31 33 422 35 55 Fax: +31 33 422 35 44	<b>NORWAY</b> AS ESAB Larvik Tel: +47 33 12 10 00 Fax: +47 33 11 52 03  <b>POLAND</b> ESAB Sp.zo.o. Katowice Tel: +48 32 351 11 00 Fax: +48 32 351 11 20  <b>PORTUGAL</b> ESAB Lda Lisbon Tel: +351 8 310 960 Fax: +351 1 859 1277  <b>ROMANIA</b> ESAB Romania Trading SRL Bucharest Tel: +40 316 900 600 Fax: +40 316 900 601  <b>RUSSIA</b> LLC ESAB Moscow Tel: +7 (495) 663 20 08 Fax: +7 (495) 663 20 09  <b>SLOVAKIA</b> ESAB Slovakia s.r.o. Bratislava Tel: +421 7 44 88 24 26 Fax: +421 7 44 88 87 41  <b>SPAIN</b> ESAB Ibérica S.A. Alcalá de Henares (MADRID) Tel: +34 91 878 3600 Fax: +34 91 802 3461  <b>SWEDEN</b> ESAB Sverige AB Gothenburg Tel: +46 31 50 95 00 Fax: +46 31 50 92 22  ESAB international AB Gothenburg Tel: +46 31 50 90 00 Fax: +46 31 50 93 60  <b>SWITZERLAND</b> ESAB AG Dietikon Tel: +41 1 741 25 25 Fax: +41 1 740 30 55  <b>UKRAINE</b> ESAB Ukraine LLC Kiev Tel: +38 (044) 501 23 24 Fax: +38 (044) 575 21 88	<b>North and South America</b> <b>ARGENTINA</b> CONARCO Buenos Aires Tel: +54 11 4 753 4039 Fax: +54 11 4 753 6313  <b>BRAZIL</b> ESAB S.A. Contagem-MG Tel: +55 31 2191 4333 Fax: +55 31 2191 4440  <b>CANADA</b> ESAB Group Canada Inc. Mississauga, Ontario Tel: +1 905 670 02 20 Fax: +1 905 670 48 79  <b>MEXICO</b> ESAB Mexico S.A. Monterrey Tel: +52 8 350 5959 Fax: +52 8 350 7554  <b>USA</b> ESAB Welding & Cutting Products Florence, SC Tel: +1 843 669 44 11 Fax: +1 843 664 57 48  <b>Asia/Pacific</b> <b>CHINA</b> Shanghai ESAB A/P Shanghai Tel: +86 21 2326 3000 Fax: +86 21 6566 6622  <b>INDIA</b> ESAB India Ltd Calcutta Tel: +91 33 478 45 17 Fax: +91 33 468 18 80  <b>INDONESIA</b> P.T. ESABindo Pratama Jakarta Tel: +62 21 460 0188 Fax: +62 21 461 2929  <b>JAPAN</b> ESAB Japan Tokyo Tel: +81 45 670 7073 Fax: +81 45 670 7001  <b>MALAYSIA</b> ESAB (Malaysia) Snd Bhd USJ Tel: +603 8023 7835 Fax: +603 8023 0225  <b>SINGAPORE</b> ESAB Asia/Pacific Pte Ltd Singapore Tel: +65 6861 43 22 Fax: +65 6861 31 95	<b>SOUTH KOREA</b> ESAB SeAH Corporation Kyungnam Tel: +82 55 269 8170 Fax: +82 55 289 8864  <b>UNITED ARAB EMIRATES</b> ESAB Middle East FZE Dubai Tel: +971 4 887 21 11 Fax: +971 4 887 22 63  <b>Africa</b> <b>EGYPT</b> ESAB Egypt Dokki-Cairo Tel: +20 2 390 96 69 Fax: +20 2 393 32 13  <b>SOUTH AFRICA</b> ESAB Africa Welding & Cutting Ltd Durbanvill 7570 - Cape Town Tel: +27 (0)21 975 8924  <b>Distributors</b> <i>For addresses and phone numbers to our distributors in other countries, please visit our home page</i>  <a href="http://www.esab.com">www.esab.com</a>
---	--	--	---



ESAB AB  
SE-695 81 LAXA  
SWEDEN  
Phone +46 584 81 000



[www.esab.com](http://www.esab.com)